



EN

EU-T-3.1
USER'S MANUAL

TECH CONTROLLERS

Safety

Changes in the merchandise described in the manual may have been introduced subsequent to its completion on 05.03.2021. The manufacturer retains the right to introduce changes to the structure or colours. The illustrations may include additional equipment. Print technology may result in differences in the colours shown.

Before using the device for the first time the user should read the following regulations carefully. Not obeying the instructions included in this manual may lead to personal injuries or controller damage.

The user's manual should be stored in a safe place for further reference. In order to avoid accidents and errors it should be ensured that every person using the device has familiarized themselves with the principle of operation as well as security functions of the controller. If the device is to be sold or put in a different place, make sure that the user's manual is there with the device so that any potential user has access to essential information about the device.

The manufacturer does not accept responsibility for any injuries or damage resulting from negligence; therefore, users are obliged to take the necessary safety measures listed in this manual to protect their lives and property.

! WARNING

- The regulator should not be operated by children.
- Any use other than specified by the manufacturer is forbidden.

EU Declaration of conformity

Hereby, we declare under our sole responsibility that **EU-T-3.1** manufactured by TECH STEROWNIKI, head-quartered in Wieprz Biała Droga 31, 34-122 Wieprz, is compliant with Directive 2014/35/EU of the European Parliament and of the Council of 26 February 2014 on the harmonisation of the laws of Member States relating to the making available on the market of electrical equipment designed for use within certain voltage limits (EU OJ L 96, of 29.03.2014, p. 357), Directive 2014/30/EU of the European Parliament and of the Council of 26 February 2014 on the harmonisation of the laws of Member States relating to electromagnetic compatibility (EU OJ L 96 of 29.03.2014, p.79), Directive 2009/125/EC establishing a framework for the setting of ecodesign requirements for energy-related products as well as the regulation by the MINISTRY OF ENTREPRENEURSHIP AND TECHNOLOGY of 24 June 2019 amending the regulation concerning the essential requirements as regards the restriction of the use of certain hazardous substances in electrical and electronic equipment, implementing provisions of Directive (EU) 2017/2102 of the European Parliament and of the Council of 15 November 2017 amending Directive 2011/65/EU on the restriction of the use of certain hazardous substances in electrical and electronic equipment (OJ L 305, 21.11.2017, p. 8). For compliance assessment, harmonized standards were used: PN-EN IEC 60730-2-9:2019-06, PN-EN 60730-1:2016-10, PN EN IEC 63000:2019-01 RoHS.

Wieprz, 28.10.2025

Paweł Jura *Janusz Master*
Paweł Jura Janusz Master
Prezesa firmy

How to install the controller

The device should be installed by a qualified person.

In order to mount the regulator on the wall, screw the rear cover onto the wall, insert batteries and slide the device into the cover.

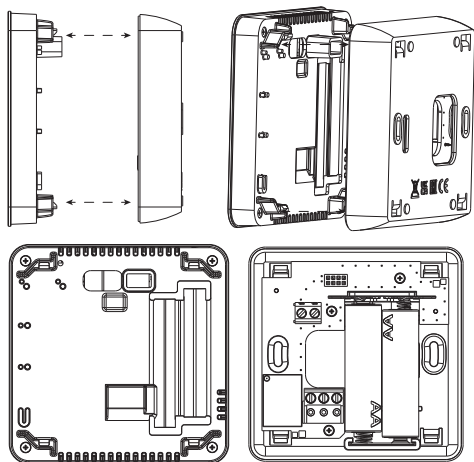

e-mail: serwis@techsterowniki.pl

phone: +48 33 875 93 80

ul. Skochnica 120, 32-652 Bulowice

Service:

ul. Biała Droga 31, 34-122 Wieprz

Central headquarters:

TECH CONTROLLERS



electric and electronic components will be recycled

We are committed to protecting the environment. Manufacturing electronic devices imposes an obligation of providing for environmentally safe disposal of used electronic components and devices. Hence, we have been entered into a register kept by the Inspection for Environmental Protection. The crossed-out bin symbol on a product means that the product may not be disposed of to household waste containers. Recycling of waste helps to protect the environment. The user is obliged to transfer their used equipment to a collection point where all

Technical data

Power supply	2xAA 1,5V alkaline batteries
Potential-free cont. nom. out. load	230V AC / 0,5A (AC1) * 24V DC / 0,5A (DC1) **
Temperature adjustment range	5°C ÷ 35°C
Measurement error	± 0,5°C

* AC1 load category: single-phase, resistive or slightly inductive AC load.

** DC1 load category: direct current, resistive or slightly inductive load.

Device description

The EU-T-3.1 room regulator is intended for controlling the heating device. Its main task is to maintain the pre-set flat/floor temperature by sending a signal to the heating device (contact closing) or the main controller which controls the actuators, when the room/floor temperature is below the pre-set value.

The EU-T-3.1 regulator functions:

- Maintaining pre-set room temperature
- Manual mode
- Day/night mode
- Constant mode
- Control of the floor sensor

Controller equipment:

- Touch buttons
- Front panel made of glass
- Built-in temperature sensor
- Batteries

There are 2 color versions: white or black.

The EU-T-3.1 room regulator - connection diagram

The room regulator should be connected to the heating device via a two-core cable. When connecting devices with over 1A load, it is necessary to use a contactor. Optionally, it is possible to connect an additional sensor to the floor sensor contact – additional functions will appear in the controller menu.

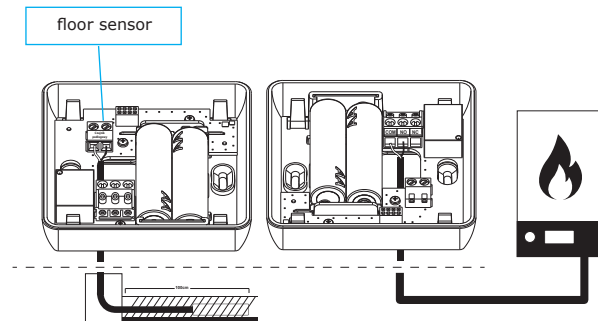

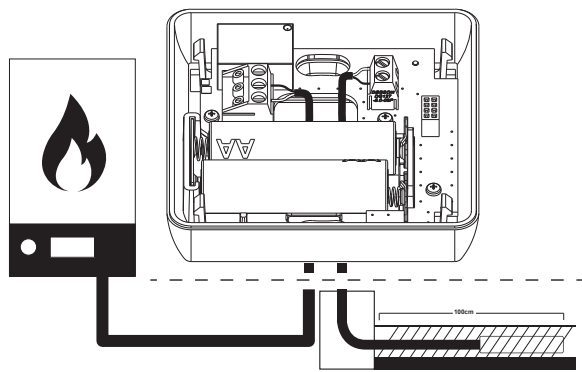

NOTE
 The regulator is powered with batteries - it is recommended to check the batteries from time to time and replace them at least once every heating season.

Device description

The user operates the device using touch buttons.

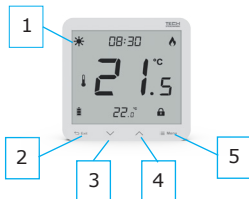

1. Display
2. **EXIT** - press this button to display the room temperature/ floor temperature or to disable manual mode.
3. - press this button to decrease the edited value.
4. - press this button to increase the edited value.
5. **MENU** - hold this button to set calibration. Press the MENU button to move on to edit next parameters.

Controller functions

The user navigates in the menu structure using touch buttons: EXIT, and and MENU. In order to edit particular parameters, press MENU. By pressing MENU the user may preview the controller functions. The edited parameter is flashing. Use the buttons and to change the parameter settings. Press MENU to confirm the changes and move on to edit the next parameter.

1. CLOCK - In order to set the time, press MENU button until a digital clock settings appear at the top of the screen. The settings concern the flashing parameter. Use or to set the hour. Next, press MENU to move to the next parameter - minutes.

2. OPERATION MODE - This function enables the user to select one of the operation modes available - constant or day/night, by selecting ON or OFF. In order to do it, press the MENU button until a mode selection screen appears. **ON** - this function is used to enable constant mode - it is possible to set constant temperature. **OFF** - this function is used to disable constant mode and enable day/night mode - it is possible to set daytime and nighttime temperatures as well as the exact time of entering each phase.

3. CONSTANT PRE-SET TEMPERATURE - After selecting ON in the operation mode selection screen, a constant temperature screen will appear. Use the buttons and to set the temperature. The temperature will apply permanently, regardless of the time of day and the setting will be saved even after restarting the device.

4. PRE-SET DAY TEMPERATURE - In order to define the pre-set day temperature, press MENU button until a flashing icon appears on the screen. Use or to set the day temperature.

5. DAY FROM... - This function enables the user to define the exact time of entering the day mode. To configure this parameter, press MENU until a flashing icon appears on the screen. Use or to set the time of day mode activation.

6. PRE-SET NIGHT TEMPERATURE - In order to define the pre-set night temperature, press MENU button until a flashing icon appears on the screen. Use or to set the night temperature.

7. NIGHT FROM... - This function enables the user to define the exact time of entering the night mode. To configure this parameter, press MENU until a flashing icon appears on the screen. Use or to set the time of night mode activation.

8. HYSTERESIS - Room temperature hysteresis defines the pre-set temperature tolerance in order to prevent undesired oscillation in case of small temperature fluctuation (within the range of 0,2 - 1°C).

Example:
 Pre-set temperature : 23°C, Hysteresis: 1°C
 The room regulator reports that the temperature is too low when the room temperature drops to 22 °C.

In order to set the hysteresis, press MENU until a flashing icon appears on the screen. Use or to set the desired hysteresis value.

9. FLOOR HEATING ON/OFF - This function is used to enable (ON) or disable (OFF) the underfloor heating, with the use of and . When the underfloor heating is enabled (icon) the user may configure the following parameters:

- **Maximum temperature** - in order to set the maximum floor temperature, press MENU until the floor heating icon appears on the screen. Next, use or to enable the heating, and then use the same buttons to set the maximum temperature.

- **Minimum temperature** - in order to set the minimum floor temperature, press MENU until the floor heating icon appears on the screen. Next, use or to enable the heating, and then use the same buttons to set the minimum temperature.

First start-up

In order for the EU-T-3.1 controller to work properly, it is necessary to follow these steps when starting the device for the first time:

1. Insert the batteries - in order to do it, remove the front cover of the controller.
2. Connect the controller to the heating device.
3. If the room regulator will be used to operate the floor heating system, connect an additional sensor to the floor sensor connector.

Operation modes

The room regulator may operate in one of the following operation modes:

- **Day/night mode** - In this mode the pre-set temperature value depends on the current time of the day. The user may set different temperature values for the daytime and nighttime as well as define the exact time of entering day mode and night mode.

In order to activate this mode, press MENU button until one of the mode icons or appears on the main screen. The user may define the pre-set temperature and (after tapping on MENU again) the time of entering day and night mode.

- **Manual mode** - In this mode, the pre-set temperature is adjusted manually from the main screen view with the use of these buttons and . Manual mode is activated after pressing MENU button. Once the manual mode has been activated, the previous operation mode enters "sleep mode" until the next pre-programmed temperature change. Manual mode may be deactivated by pressing EXIT button.

- **Constant mode** - In this mode, the pre-set temperature will apply all the time, regardless of the time of day.

Main screen description

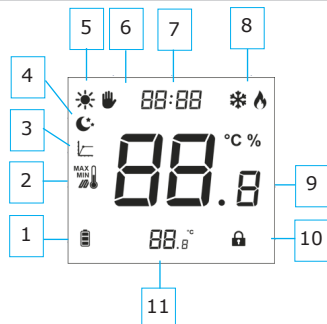

1. Battery level
2. Maximum/minimum floor temperature - this icon is displayed only when the floor sensor is enabled in the controller menu.
3. Hysteresis
4. Night mode
5. Day mode
6. Manual mode
7. Current time
8. Cooling/heating
9. Current temperature
10. Button lock
11. Pre-set temperature

- **Hysteresis** - underfloor heating hysteresis defines the tolerance for the maximum and minimum temperature. The settings range is from 0,2°C to 1 °C.

If the floor temperature exceeds the maximum temperature, the underfloor heating will be disabled. It will be enabled only after the temperature has dropped below the maximum floor temperature minus the hysteresis value.

Example:
 Maximum floor temperature: 33°C, Hysteresis: 1°C
 When the floor temperature reaches 33°C, the underfloor heating will be disabled. It will be activated again when the temperature drops to 32°C. If the floor temperature drops below the minimum temperature, the underfloor heating will be enabled. It will be disabled after the floor temperature has reached the minimum value plus the hysteresis value
 Example:
 Minimum floor temperature: 23°C, Hysteresis: 1°C
 When the floor temperature drops to 23°C, the underfloor heating will be enabled. It will be disabled when the temperature reaches 24°C.

10. BUTTON LOCK ON/OFF - It is possible to activate button lock. In order to do it, press the MENU button until the icon appears on the screen and select ON. In order to unlock the buttons, press and hold any button.

Menu button functions

By holding the MENU button the user may enter particular functions in the Menu.

1. COOLING/HEATING - This function allows you to select the operating mode: heating (HEA) or cooling (COO). Depending on the selected mode, an icon will appear on the main screen.

2. BUILT-IN SENSOR CALIBRATION - Calibration should be performed while mounting or after it has been used for a long time, if the room temperature measured by the sensor differs from the actual temperature. Calibration setting range is from -10 to +10 °C with the accuracy of 0,1°C.

To calibrate the built-in sensor, press the MENU button until the temperature sensor calibration screen appears. Use the buttons or to set the desired correction. To confirm, press the MENU button (confirm and go on to edit the next parameter).

3. FLOOR SENSOR CALIBRATION - Floor sensor calibration (an additional icon is displayed:) should be performed if the floor temperature measured by the sensor differs from the actual temperature. To calibrate the built-in sensor, press the MENU button until the floor sensor calibration screen appears. Use the buttons or to set the desired correction. To confirm, press the MENU button (confirm and go on to edit the next parameter).

4. MIN/MAX TEMPERATURE - This function allows you to set the minimum and maximum temperature of the built-in sensor. Confirm the settings by pressing the Menu button.

5. SOFTWARE VERSION - After pressing the MENU button the user may check the software version number. The number is necessary while contacting the service staff.

6. DEFAULT SETTINGS - This function allows the user to restore the manufacturer's factory settings (YES, NO). Confirm the selection by pressing the Menu button.