

TECH TECH CONTROLLERS

USER MANUAL EU-i-1 CWU

EN



www.tech-controllers.com

TABLE OF CONTENTS

1	Safety	3
2	Description of the device	4
3	How to install	5
4	how to use the controller.....	7
4.1	CH screen	8
4.2	Valve screen.....	9
4.3	Controller functions – main menu.....	10
4.3.1	Pre-set valve temperature	10
4.3.2	ON / OFF.....	10
4.3.3	DHW	10
4.3.4	Pump operation modes.....	11
4.3.5	DHW weekly control.....	12
4.3.6	Screen view	14
4.3.7	Manual mode	14
4.3.8	Fitter’s menu	14
4.3.9	Service menu	14
4.3.10	Screen settings.....	14
4.3.11	Language	15
4.3.12	Factory settings.....	15
4.3.13	Software version	15
4.4	Controller function– fitter’s menu.....	15
4.4.1	TECH regulator	15
4.4.2	Voltage-free contact.....	16
4.4.3	Valve settings	17
4.4.4	Time settings	25
4.4.5	Date settings.....	25
4.4.6	GSM module.....	26
4.4.7	Internet module	26
4.4.8	External sensor calibration.....	28
4.4.9	Software update.....	28
4.4.10	Factory settings.....	28
5	Protections and alarms	29
6	Technical data	29

1 SAFETY



Before using the device for the first time the user should read the following regulations carefully. Not obeying the rules included in this manual may lead to personal injuries or controller damage. The user's manual should be stored in a safe place for further reference. In order to avoid accidents and errors it should be ensured that every person using the device has familiarized themselves with the principle of operation as well as security functions of the controller. If the device is to be sold or put in a different place, make sure that the user's manual is there with the device so that any potential user has access to essential information about the device.

The manufacturer does not accept responsibility for any injuries or damage resulting from negligence; therefore, users are obliged to take the necessary safety measures listed in this manual to protect their lives and property.



WARNING

- High voltage! Make sure the regulator is disconnected from the mains before performing any activities involving the power supply (plugging cables, installing the device etc.)
- The device should be installed by a qualified electrician.
- Before starting the controller, the user should measure earthing resistance of the electric motors as well as the insulation resistance of the cables.
- The regulator should not be operated by children.



WARNING

- The device may be damaged if struck by a lightning. Make sure the plug is disconnected from the power supply during storm.
- Any use other than specified by the manufacturer is forbidden.
- Before and during the heating season, the controller should be checked for condition of its cables. The user should also check if the controller is properly mounted and clean it if dusty or dirty.

Changes in the merchandise described in the manual may have been introduced subsequent to its completion on 11.02.2026. The manufacturer retains the right to introduce changes to the structure. The illustrations may include additional equipment. Print technology may result in differences in colours shown.



We are committed to protecting the environment. Manufacturing electronic devices imposes an obligation of providing for environmentally safe disposal of used electronic components and devices. Hence, we have been entered into a register kept by the Inspection For Environmental Protection. The crossed-out bin symbol on a product means that the product may not be disposed of to household waste containers. Recycling of wastes helps to protect the environment. The user is obliged to transfer their used equipment to a collection point where all electric and electronic components will be recycled.

2 DESCRIPTION OF THE DEVICE



EU-H CWU thermoregulator is intended for controlling a three- or four-way mixing valve with the possibility of connecting additional valve pump. Optionally, the controller may cooperate with two valve modules i-1, i-1M or ST-431N which makes it possible to control up to 3 mixing valves. The controller features weather-based control, weekly control schedule and it may cooperate with a room regulator. Another asset of the device is return temperature protection against too cold water returning to the CH boiler.

Functions offered by the controller:

- Smooth control of a three- or four-way valve
- Pump control
- Controlling two additional valves via additional valve modules (e.g. ST-61v4, i-1)
- Possibility of connecting ST-505 ETHERNET, WiFi RS
- Return temperature protection
- Weekly and weather-based control
- Compatible with RS and two-state room regulators

Controller equipment:

- LCD display
- CH boiler temperature sensor
- Valve temperature sensor
- Return temperature sensor
- External weather sensor
- DHW sensor
- Wall-mountable casing

3 HOW TO INSTALL



The controller should be installed by a qualified person.



WARNING

Incorrect connection of wires may damage the regulator!

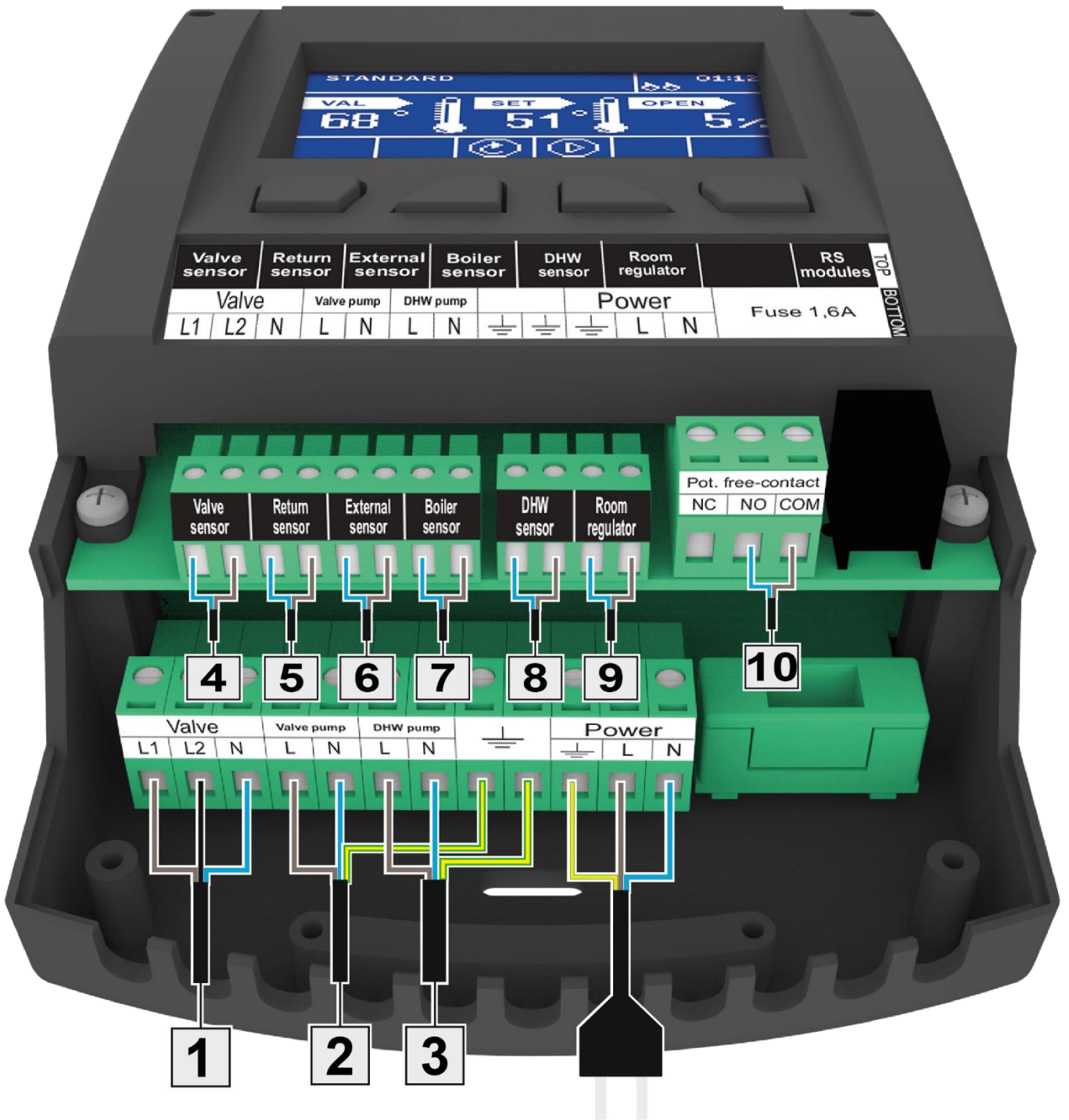

Example installation scheme:

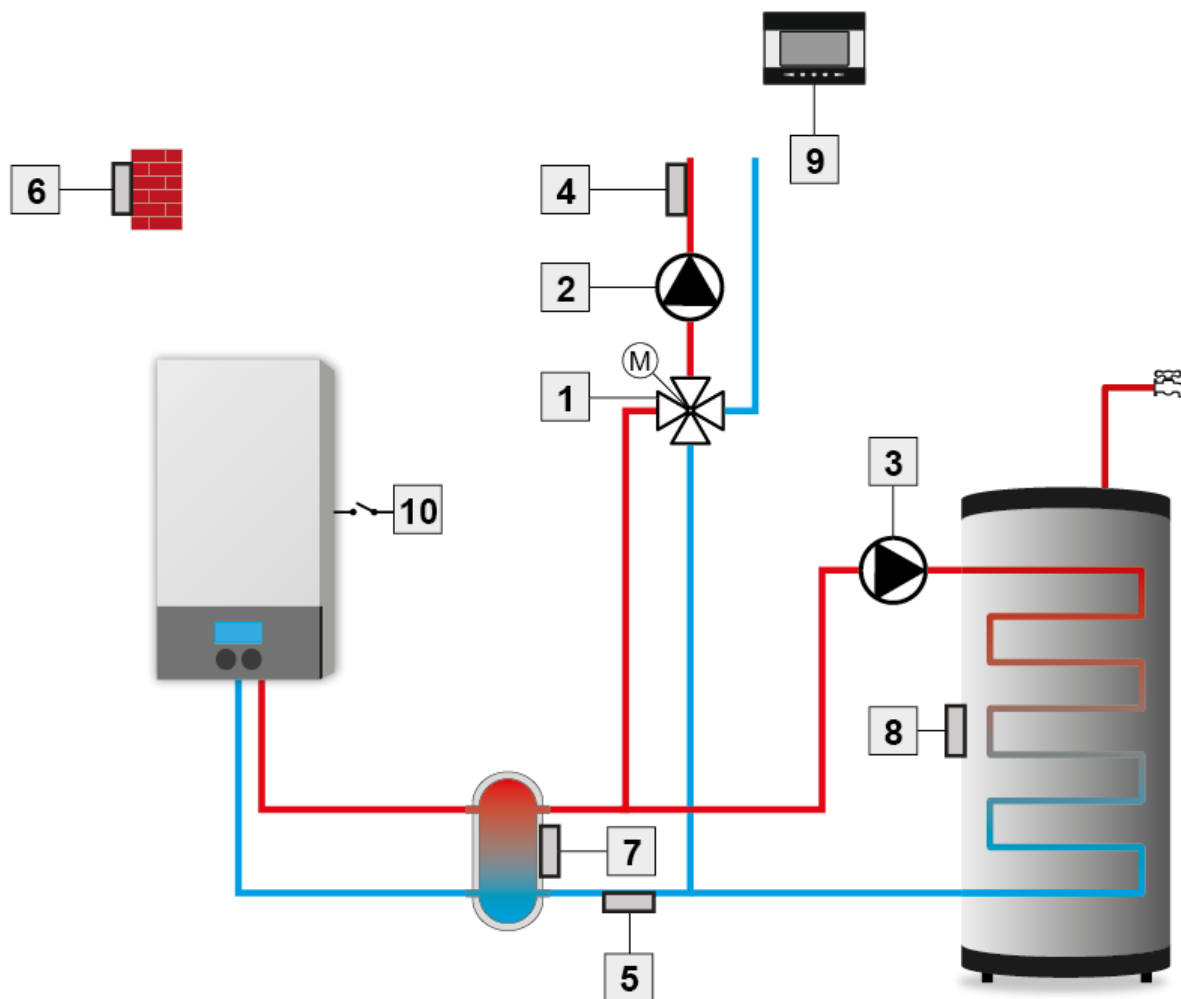

- | | |
|------------------|--------------------------|
| 1. Valve | 6. Weather sensor |
| 2. Valve pump | 7. CH boiler sensor |
| 3. DHW pump | 8. DHW sensor |
| 4. Valve sensor | 9. Room regulator |
| 5. Return sensor | 10. Voltage-free contact |

4 HOW TO USE THE CONTROLLER



There are 4 buttons used to control the device.

- ⇒ **EXIT** - in the main screen view it is used to open up the screen view selection panel. In the menu it is used to exit the menu and cancel the settings.
- ⇒ **MINUS** - in the main screen view it is used to decrease the pre-set valve temperature. In the menu it is used to navigate through menu options and decrease the edited value.
- ⇒ **PLUS** - in the main screen view it is used to increase the pre-set valve temperature. In the menu it is used to navigate through menu options and increase the edited value.
- ⇒ **MENU** - it is used to enter the menu and confirm the settings.

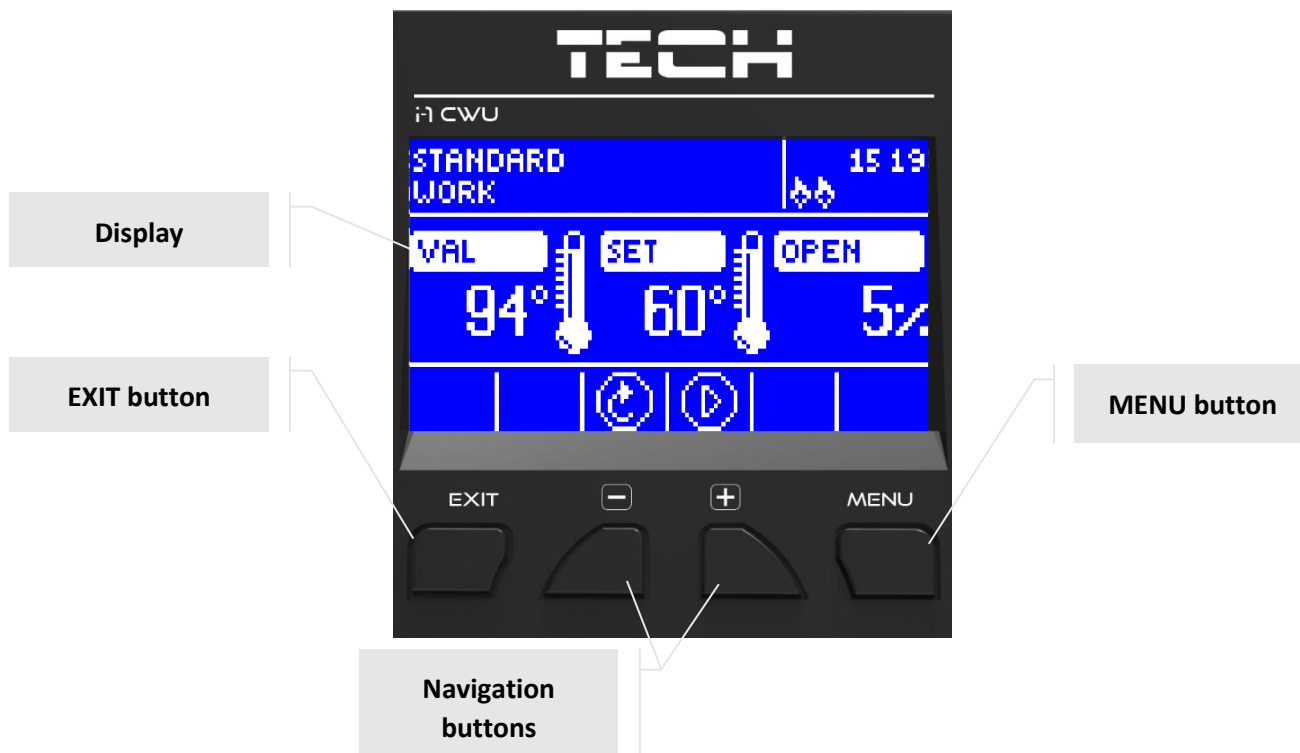

4.1 CH SCREEN

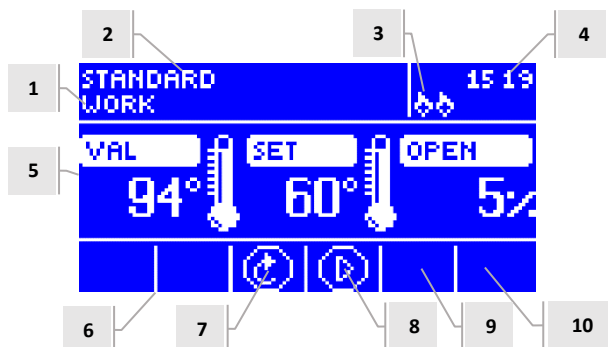

1. Valve status:
 - OFF
 - Operation
 - CH boiler protection -it is displayed on the screen when CH boiler protection is activated; i.e. when the temperature increases to the value defined in the settings.
 - Return protection - it is displayed on the screen when return protection is activated; i.e. when the return temperature is lower than the threshold temperature defined in the settings.
 - Calibration
 - Floor overheating
 - Alarm
 - Stop – it appears in *Summer mode* when *Closing below threshold* function is active - when CH temperature is lower than the pre-set value or when Room regulator function -> Closing is active - when the room temperature has been reached.
2. Controller operation mode
3. „P” is displayed in this place when a room regulator is connected to i-1 module.
4. Current time
5. From the left:
 - Current valve temperature
 - Pre-set valve temperature
 - Level of valve opening
6. Icon indicating that additional module (of valve 1 and 2) is switched on.
7. Icon indicating valve status or selected valve type (CH, floor or return protection).
8. Icon indicating valve pump operation
9. Icon indicating DHW pump operation
10. Information about voltage-free contact

ICON	Description
	Additional valve module - the icon is displayed in the area no. 6 - valve 1 or 2 module. It is displayed after the additional valve-controlling module (e.g. i-1, ST-61v4) has been connected and registered.
	Icon displayed in the area no. 7. It indicates that the controller manages CH valve - MENU -> Fitter’s menu -> Built-in valve -> Valve type -> CH valve).
	Icon displayed in the area no. 7. It indicates that the controller manages floor valve - MENU -> Fitter’s menu -> Built-in valve -> Valve type -> floor valve).
	Icon displayed in the area no. 7. It indicates that the controller manages return protection - MENU -> Fitter’s menu -> Built-in valve -> Valve type -> Return protection).
	Icon displayed in the area no. 7. It indicates that valve calibration is active.
	Icon displayed in the area no. 8. It is displayed during pump operation.
	Icon displayed in the area no. 9. It indicates DHW pump operation
	Icon displayed in the area no. 10. It refers to the voltage-free contact.

4.2 VALVE SCREEN

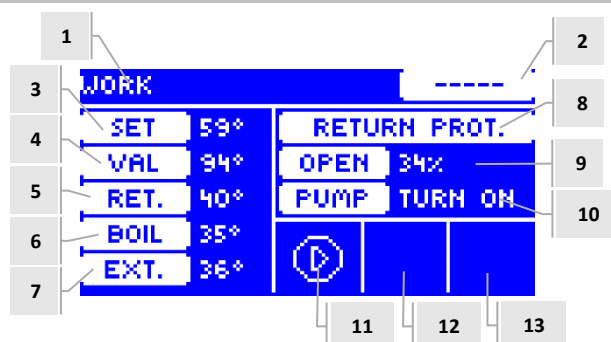

1. Valve status – as in CH screen
2. Valve address
3. Pre-set valve temperature and change
4. Current valve temperature
5. Current return temperature
6. Current CH boiler temperature
7. Current external temperature
8. Valve type
9. Percent of opening
10. Valve pump operation mode
11. Valve pump status
12. Information about the connected room regulator or weather-based control mode
13. Information about active communication with a subordinate controller.

ICON	Description
	Valve pump mode icon - it is displayed in the area no. 11. It indicates that the pump is switched on and active.
	Room regulator icon - it is displayed in the area no. 12. It indicates that a room regulator is connected to the valve controller.
	Icon indicating that the pre-set room temperature has been reached. It is displayed in the area no. 12.
	Weather-based control icon - it is displayed in the area no. 12. It indicates that the valve operates in weather-based control mode.
	Communication icon - it is displayed in the area no. 13. It indicates communication in subordinate mode.

4.3 CONTROLLER FUNCTIONS – MAIN MENU



Main menu offers basic controller options.

MAIN MENU	Pre-set valve temperature
	ON/OFF
	DHW
	Pump operation modes
	Screen view
	Manual mode
	Fitter’s menu
	Service menu
	Screen settings
	Language
	Factory settings
	Software version

4.3.1 Pre-set valve temperature

This option is used to set desired temperature which the valve is to maintain. During proper operation the temperature of water downstream of the valve approximates the pre-set valve temperature.

4.3.2 ON / OFF

This option enables the user to activate the mixing valve. When the valve is switched off, the pump is also inactive. The valve is always calibrated when the controller is connected to the mains even if the valve is deactivated. It prevents the valve from remaining in a position which may cause danger to the heating circuit.

4.3.3 DHW

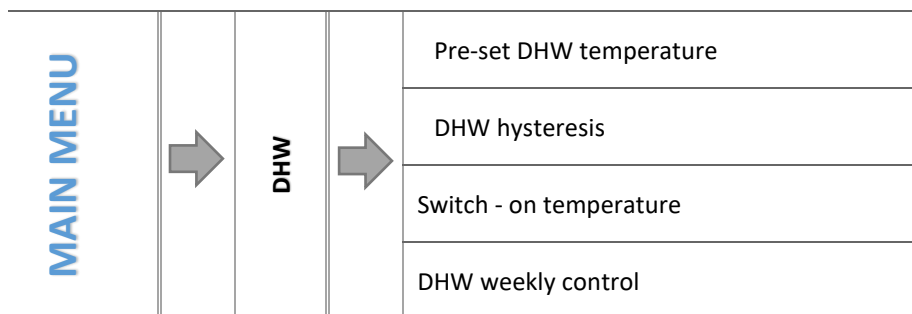

4.3.3.1 Pre-set DHW temperature

This option is used to define the pre-set temperature of domestic hot water. Once the temperature is reached, DHW pump is disabled. It will be enabled again when the temperature drops below the pre-set value by DHW hysteresis value (read from DHW sensor). DHW temperature setting range is 40°C-70°C.

4.3.3.2 DHW hysteresis

This option is used to set the hysteresis of the pre-set water tank temperature. It is the difference between the pre-set temperature (desired temperature of the water tank) and the temperature of returning to operation mode.

Example:

Pre-set DHW temperature	55°C
Hysteresis	5°C
Pump deactivation	55°C
Next pump activation	50°C

When the pre-set temperature is 55°C, and the hysteresis is 5°C, the device will be disabled when the temperature of 55°C is reached. Operation mode will be restored when the temperature drops to 50°C.

4.3.3.3 Switch-on temperature

This option is used to set the temperature of DHW pump activation (the temperature measured at the CH boiler). Below this temperature the pump remain inactive and above this temperature the pump is enabled and operates in one of the operation modes available:

4.3.4 Pump operation modes

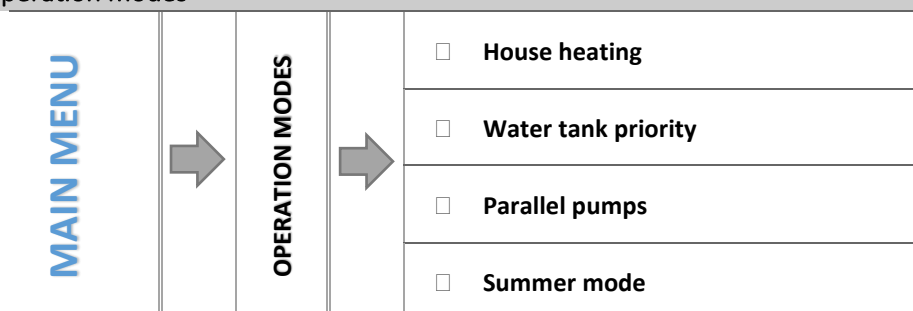

This function enables the user to choose one of the valve operation modes depending on individual needs:

4.3.4.1 House heating

Once this function is selected, only the house is heated. When *ON above threshold* function is selected, CH pump is activated when the temperature is above the pump activation threshold. Below this temperature value (minus hysteresis) the pump is disabled.

4.3.4.2 Water tank priority

In this mode, the DHW pump operates until the pre-set DHW temperature is reached (the valves close completely and the valve pumps are switched off). After the pre-set temperature has been reached, the pump is switched off and the mixing valves and valve pump are activated.

When the water tank temperature drops below the pre-set value minus hysteresis, the valve pumps are disabled and the DHW pump is activated.



NOTE

If the pre-set water tank temperature is higher than the CH boiler temperature, the pump will not be activated in order not to cool down the water.

4.3.4.3 Parallel pumps

In this mode, CH pump operates all the time. DHW pump is activated simultaneously to heat the water tank and it is disabled when the pre-set DHW temperature is reached. It will be activated again when the temperature drops below the pre-set value by DHW hysteresis value. When SUMMER mode is selected, only DHW pump is active.



NOTE

If current CH boiler temperature is lower than current water tank temperature, DHW pump will not be activated in order not to cool down the water in the water tank (if the temperature drops below **6°C, DHW pump will be enabled**).

4.3.4.4 Summer mode

In this mode, only DHW pump is active (above pump activation threshold). **CH valves** are closed to prevent unnecessary house heating. If the CH boiler temperature is too high, the valve will be opened as an emergency procedure (it requires activation of return protection).

4.3.5 DHW weekly control

This function enables the user to program daily changes of the pre-set DHW temperature for particular time and day of the week. The settings range for the temperature changes is -40°C to 20°C.

In order to activate weekly control, select *Mode 1* or *Mode 2*. Detailed settings of each mode are provided in the following sections: Set mode 1 and Set mode 2.



NOTE

It is necessary to set current date and time in order for this function to work properly.

- **WEEKLY CONTROL SETTING**

Weekly control may be programmed in two different modes:

MODE 1 – the user sets the temperature deviations for each day of the week separately

Configuring Mode 1:

- ⇒ Select: Set mode 1.
- ⇒ Select the day of the week to be edited
- ⇒ The following screen appears on the display
- ⇒ Use the buttons +/ - to select the time for which you want to change the temperature and confirm the selection by pressing the MENU button.
- ⇒ The bottom of the screen will show some options - select CHANGE by pressing the MENU button when it is highlighted in white.
- ⇒ Decrease or increase the temperature by the selected value and confirm.
- ⇒ Changes of the pre-set temperature can be made within the range of -40 ° C to 20 ° C.
- ⇒ If you want to apply the same change also to the next hours, press the MENU button on the selected setting, select COPY in the bottom part of the screen and copy the setting to the next or previous hour using the buttons +/ - . Confirm the settings by pressing the MENU button.

Example:

	Time	Temperature - weekly control setting (+/-)
Monday		
PRE-SET	4 ⁰⁰ - 7 ⁰⁰	+5°C
	7 ⁰⁰ - 14 ⁰⁰	-10°C
	17 ⁰⁰ - 22 ⁰⁰	+7°C

If the pre-set DHW temperature is 50°C, on Mondays between 4⁰⁰ and 7⁰⁰ it will increase by 5°C to reach 55°C; between 7⁰⁰ and 14⁰⁰ it will drop by 10°C, to reach 40°C, and between 17⁰⁰ and 22⁰⁰ it will increase to reach 57°C.

MODE 2 – the user sets the temperature deviations for all working days (Monday-Friday) and for the weekend (Saturday-Sunday) separately.

Configuring mode 2:

- ⇒ Select: Set mode 2.
- ⇒ Select the part of the week to be edited.
- ⇒ Follow the same procedure as in the case of Mode 1.

Example:

	Time	Temperature - weekly control setting (+/-)
Monday - Friday		
PRE-SET	4 ⁰⁰ - 7 ⁰⁰	+5°C
	7 ⁰⁰ - 14 ⁰⁰	-10°C
	17 ⁰⁰ - 22 ⁰⁰	+7°C
Saturday - Sunday		
PRE-SET	6 ⁰⁰ - 9 ⁰⁰	+5°C
	17 ⁰⁰ - 22 ⁰⁰	+7°C

If the pre-set CH boiler temperature is 50°C, from Monday to Friday between 4⁰⁰ and 7⁰⁰ the CH boiler will increase by 5°C to reach 55°C; between 7⁰⁰ and 14⁰⁰ it will drop by 10°C, to reach 40°C, and between 17⁰⁰ and 22⁰⁰ it will increase to reach 57°C.

At the weekend, between 6⁰⁰ and 9⁰⁰ the temperature will increase by 5°C to reach 55°C, and between 17⁰⁰ and 22⁰⁰ it will increase to reach 57°C.

4.3.6 Screen view

This option is used to adjust the main screen layout by choosing between CH view, sensors temperature view, return protection view or the view with parameters of one built-in or additional valve (only when the valves are active). When sensors temperature view is selected, the screen displays the valve temperature (current value), current CH boiler temperature, current return temperature and external temperature. In valve 1 and valve 2 view the screen displays parameters of the selected valve: current and pre-set temperature, external temperature, return temperature, percent of valve opening.

4.3.7 Manual mode

This option is used to manually open/close the valve (and additional valves if active) as well as to switch the pump on/off in order to check if the devices work properly.

4.3.8 Fitter’s menu

Functions available in the Fitter’s menu should be configured by qualified fitters and concern advanced parameters of the controller.

➔ 4.4 Controller function– fitter’s menu , page: 15

4.3.9 Service menu

Functions available in this submenu should be accessed only by service staff and qualified fitters. Access to this menu is secured with a code provided by Tech.

4.3.10 Screen settings

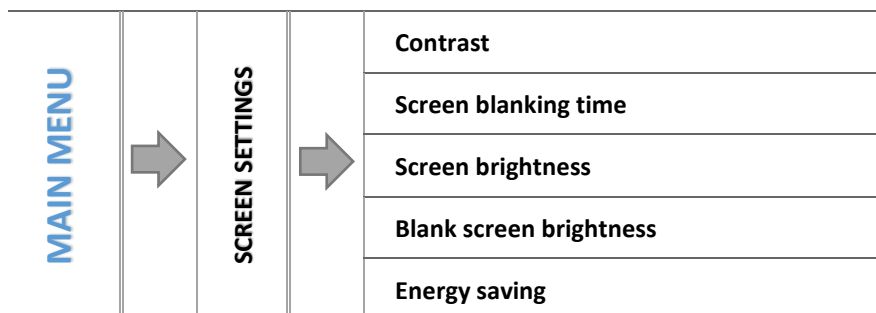

Screen settings may be customized to satisfy the user’s needs.

4.3.10.1 Contrast

This function enables the user to adjust the display contrast.

4.3.10.2 Screen blanking time

This function enables the user to set the screen blanking time (the screen brightness is reduced to the user-defined level - *Blank screen brightness* parameter).

4.3.10.3 Screen brightness

This function enables the user to adjust the screen brightness during standard operation e.g. while viewing the options, changing the settings etc.

4.3.10.4 Blank screen brightness

This function enables the user to adjust the brightness of the blank screen which is activated automatically after a pre-defined period of inactivity.

4.3.10.5 Energy saving

Once this option is activated, the screen brightness is automatically reduced by 20%.

4.3.11 Language

This option is used to choose the language version of the controller menu.

4.3.12 Factory settings

The controller is pre-configured for operation. However, the settings should be customized to the user's needs. Return to factory settings is possible at any time. Once the factory settings option is activated, all customized CH boiler settings are lost and replaced with the manufacturer's settings. Then, the valve parameters may be customized anew.

4.3.13 Software version

This option is used to view the software version number - the information is necessary when contacting the service staff.



4.4 CONTROLLER FUNCTION— FITTER'S MENU

Fitter's menu options should be configured by qualified users. They concern advanced parameters of controller operation.

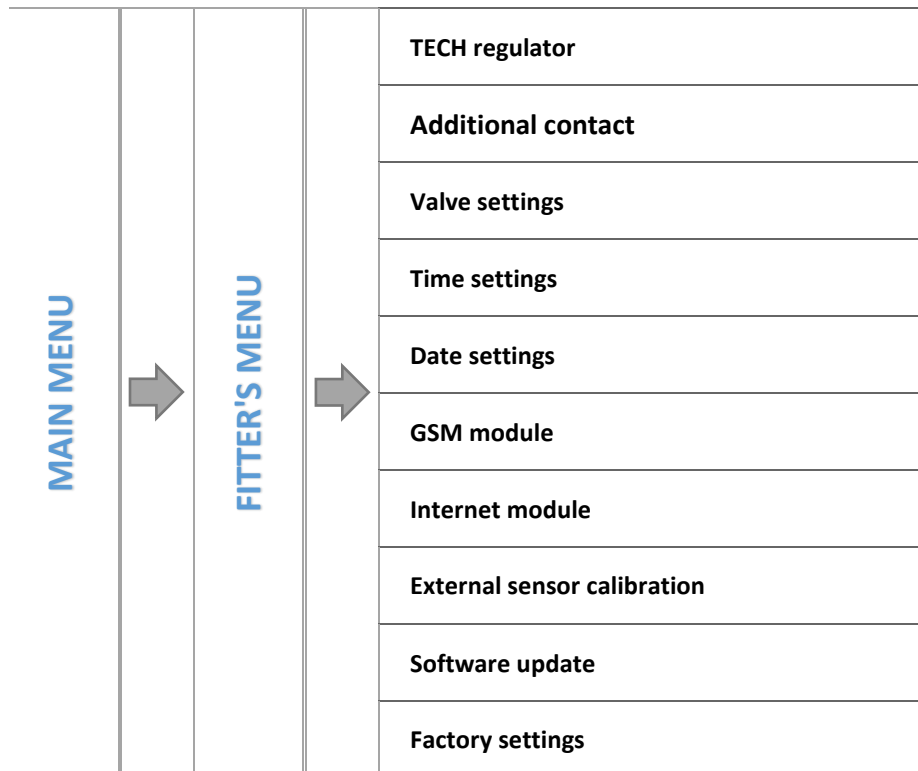

4.4.1 TECH regulator

It is possible to connect a room regulator with RS communication to i-1 controller. This option allows the user to configure the regulator by selecting ON option.



NOTE

In order for i-1 CWU controller to cooperate with the room regulator with RS communication, it is necessary to set the communication mode to *main*. Appropriate option should also be selected in Room regulator submenu.

4.4.2 Voltage-free contact

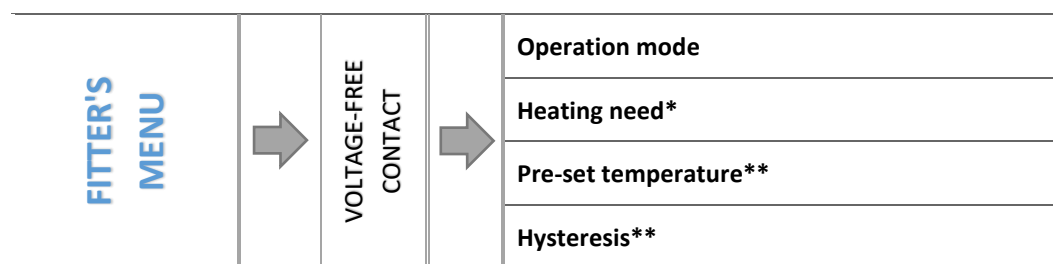

**This option is available only in the Heating need mode.*

*** This option is available only when the CH boiler mode is enabled.*

The parameters in this submenu enable the user to configure the device connected to the voltage-free contact output. The contact will be activated when any of the selected devices reports too low temperature.

4.4.2.1 Operation mode

By selecting the operation mode, the user chooses which sensor will be used to provide data. In the Heating need mode, data is provided by the DHW sensor or the regulator whereas in the CH boiler mode, the contact is controlled on the basis of the data provided by the CH sensor.

If any of the modes is enabled, additional functions appear in the voltage-free contact menu.

4.4.2.2 Heating need

In this submenu, the user decides which device will provide data: TECH regulator, Standard regulator or DHW (sensor).

4.4.2.3 pre-set temperature

This option enables the user to set the desired temperature, which the controller has to maintain. During proper operation, the temperature of water in the DHW tank approximates to the pre-set value.

4.4.2.4 Hysteresis

This option is used to set the hysteresis of the pre-set DHW temperature. It is the difference between the pre-set temperature and the temperature at which DHW is no longer heated.

Example:

Pre-set temperature	50°C
Hysteresis	2°C
Heating starts at	48°C
Heating stops at	52°C

When the pre-set temperature is 50°C and hysteresis is 2°C, heating is enabled at the temperature of 48°C and it is disabled when the temperature reaches 52°C.

4.4.3 Valve settings

This submenu is divided into two parts corresponding to particular valves - a built-in valve and up to two additional valves. Additional valve parameters may be accessed only after the valves have been registered.

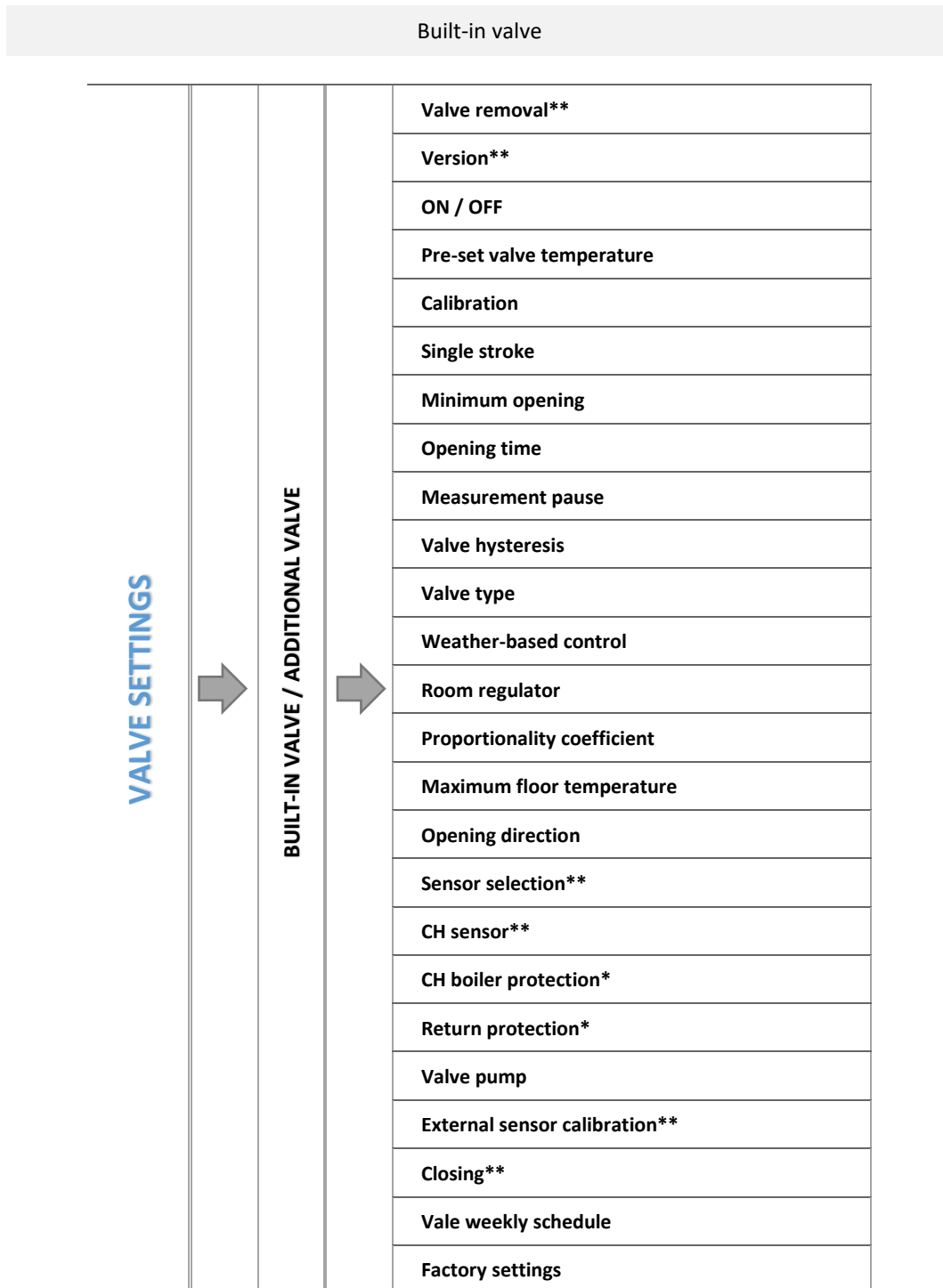

**for built-in valve only / **for additional valve only*

4.4.3.1 Registration

In the case of using additional valves, it is necessary to register the valve by entering its module number before its parameters may be configured.

If i-1 RS valve module is used, it must be registered. The registration code may be found on the rear cover or in software version submenu (i-1 valve: MENU -> Software version).

The remaining valve settings may be found in Service menu. EU-i-1CWU controller should be set as subordinate and the user should choose the sensors according to individual needs.

4.4.3.2 Valve removal



NOTE

This option is available only for an additional valve (external module).

This option is used to remove the valve from the controller memory. Valve removal is used e.g. at disassembling the valve or module replacement (re-registration of a new module is necessary).

4.4.3.3 Version

This option is used to check the software version used in the subordinate module.

4.4.3.4 ON / OFF

In order for the valve to be active, select ON. To deactivate the valve temporarily, select OFF.

4.4.3.5 Pre-set valve temperature

This option is used to set desired temperature which the valve is to maintain. During proper operation the temperature of water downstream of the valve approximates the pre-set valve temperature.

4.4.3.6 Calibration

This function enables the user to calibrate the built-in valve at any time. During this process the valve is restored to its safe position – in the case of CH valve it is fully opened whereas in the case of floor valve it is closed.

4.4.3.7 Single stroke

This is a maximum single stroke (opening or closing) that the valve may make during one temperature sampling. If the temperature is near the pre-set value, the stroke is calculated on the basis of *proportionality coefficient* parameter value. The smaller the single stroke, the more precisely the set temperature can be achieved. However, it takes longer for the set temperature to be reached.

4.4.3.8 Minimum opening

The parameter determines the smallest valve opening. Thanks to this parameter, the valve may be opened minimally, to maintain the smallest flow.

4.4.3.9 Opening time

This parameter defines the time needed for the valve to open from 0% to 100% position. This value should be set in accordance with the specification given on the actuator rating plate.

4.4.3.10 Measurement pause

This parameter determines the frequency of water temperature measurement (control) behind the CH valve. If the sensor indicates a change in temperature (deviation from the pre-set value), the electric valve will open or close by the pre-set stroke, in order to return to the pre-set temperature.

4.4.3.11 Valve hysteresis

This option is used to set the hysteresis of the pre-set valve temperature. It is the difference between the pre-set (desired) temperature and the temperature at which the valve will start closing or opening.

Example:

Pre-set valve temperature	50°C
Hysteresis	2°C
Valve stops at	50°C
Valve closing	48°C
Valve opening	52°C

When the pre-set temperature is 50°C and the hysteresis value is 2°C, the valve stops in one position when the temperature of 50°C is reached. When the temperature drops to 48°C, the valve starts opening. When the temperature of 52°C is reached, the valve starts closing in order to reduce the temperature.

4.4.3.12 Valve type

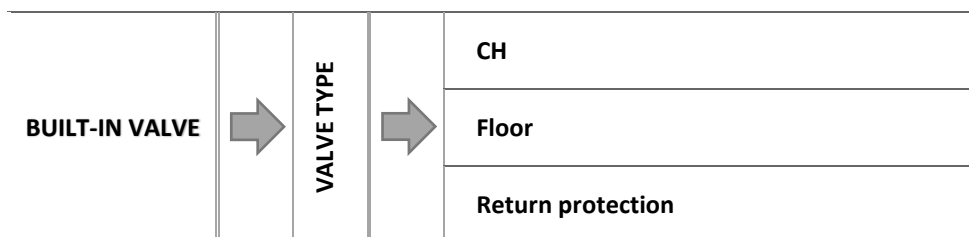

With this option the user chooses the type of valve to be controlled:

- **CH** - select if you want to control the temperature of the CH circuit using the valve sensor. The valve sensor should be installed downstream of the mixing valve on the supply pipe.
- **FLOOR** - select if you want to control the temperature of the underfloor heating circuit. It protects the underfloor heating system against dangerous temperature. If the user selects CH as the valve type and connects it to the underfloor heating system, the fragile floor installation may be damaged.
- **RETURN PROTECTION** - select if you want to control the return temperature using the return sensor. When this type of valve is selected, only return and CH boiler sensors are active whereas the valve sensor should not be connected to the controller. In this mode, the valve priority is to protect the CH boiler return against low temperature. When *CH boiler protection* option is selected as well, the valve also protects the CH boiler against overheating. When the valve is closed (0% opening), water flows only through the short circuit whereas when the valve is open (100% opening), the short circuit is closed and water flows through all the heating system.



WARNING

When CH boiler protection is active, CH temperature does not influence the valve opening. In extreme cases it may cause CH boiler overheating. Therefore, it is advisable to configure CH boiler protection settings.

4.4.3.13 Weather-based control

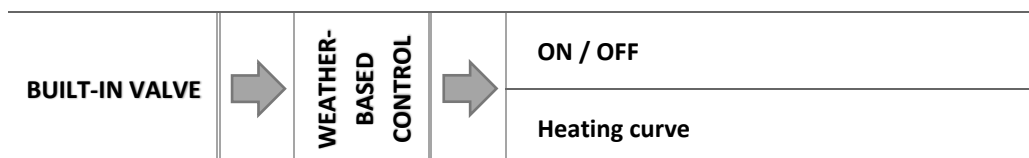

For the function of weather control to be active, the external sensor mustn't be exposed to sunlight or influenced by the weather conditions. After it is installed in an appropriate place, weather control function needs to be activated in the controller menu.

4.4.3.13.1 Heating curve

Heating curve - a curve according to which the pre-set controller temperature is determined, on the basis of external temperature. In our controller, this curve is constructed on the basis of four pre-set temperatures (downstream of the valve) for respective values of external temperatures -20°C, -10°C, 0°C and 10°C.

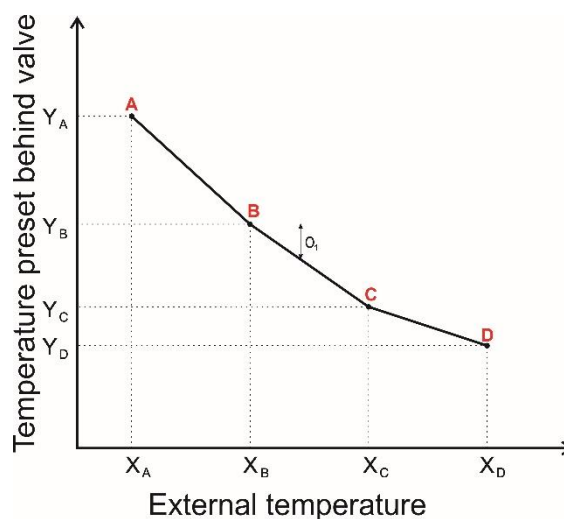

4.4.3.14 Room regulator

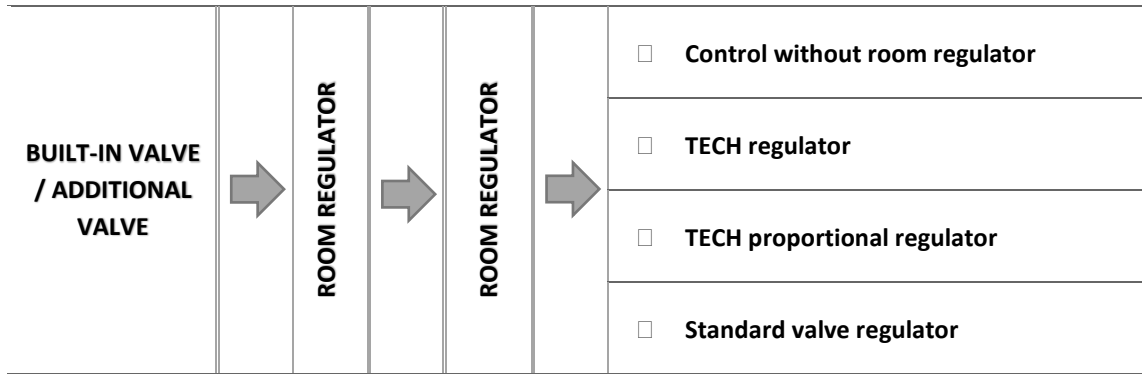

This submenu is used to configure the parameters of room regulator which is to control the valve.

4.4.3.14.1 Control without room regulator

When this option is selected, room regulator does not influence the valve operation.

4.4.3.14.2 TECH regulator

The valve is controlled by a room regulator with RS communication. When this function is selected, the regulator operates according to *Room reg. temp. lower* parameter.

4.4.3.14.3 TECH proportional regulator

This type of regulator allows the user to view current temperatures of the CH boiler, water tank and the valves. It should be connected to RS socket of the controller. When this type of room regulator is selected, the valve is controlled according to *Change in the set temp.* and *Room temperature difference* parameters.

4.4.3.14.4 Standard valve regulator

When this option is selected, the valve is controlled by a standard two-state regulator (without RS communication). The controller operates according to *Room reg. temp. lower* parameter.

4.4.3.14.5 Room regulator options

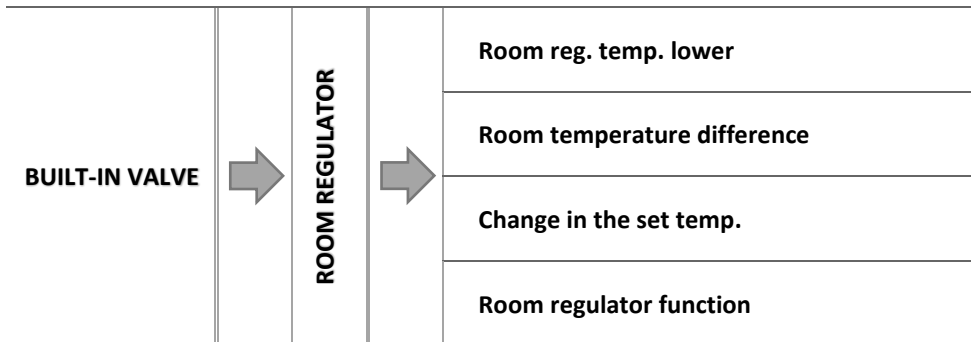

- Room reg. temp. lower



NOTE

This parameter concerns Standard valve regulator and TECH regulator.

The user defines the temperature value by which the pre-set valve temperature will be reduced when the pre-set room regulator temperature is reached.

- Room temperature difference



NOTE

This parameter concerns *TECH proportional regulator* function.

This setting is used to define a single change in the current room temperature (with the accuracy of 0.1°C) at which a predefined change in the pre-set temperature of the valve is introduced

- Change in the set temp.



NOTE

This parameter concerns *TECH* proportional regulator function.

This setting determines by how many degrees the valve temperature is to increase or decrease with a single unit change in room temperature (see: Room temperature difference) This function is active only with *TECH* room regulator and it is closely related to the Room temperature difference parameter.

Example:

<u>SETTINGS:</u>	
Room temperature difference	0,5°C
Change in the set temp.	1°C
Pre-set valve temperature	40°C
Pre-set temperature of room regulator	23°C

Case 1:

If the room temperature rises to 23,5°C (0,5°C above the pre-set room temperature), the valve closes until 39°C is reached (1°C change).

Case 2:

If the room temperature drops to 22°C (1°C below the pre-set room temperature), the valve opens until 42°C is reached (2°C change - because every 0,5°C of room temperature difference, the pre-set valve temperature changes by 1°C).

- Room regulator function

This function is used to decide if the valve should close or the temperature should decrease when the pre-set temperature has been reached.

4.4.3.15 Proportionality coefficient

Proportionality coefficient is used for defining valve stroke. The closer to the pre-set temperature, the smaller the stroke. If the coefficient value is high, the valve takes less time to open but at the same time the opening degree is less accurate. The following formula is used to calculate the percent of a single opening:

$$\text{percent of a single opening} = (\text{set temperature} - \text{sensor temperature}) \cdot \frac{\text{proportionality coefficient}}{10}$$

4.4.3.16 Opening direction

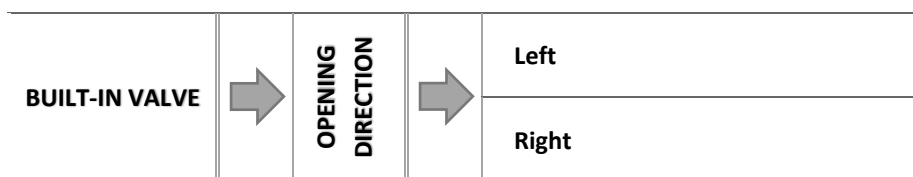

If, after connecting the valve to the controller, it turns out that it is connected the other way round, then the power supply cables do not have to be switched. Instead, it is enough to change the opening direction in this parameter: LEFT or RIGHT.

4.4.3.17 Maximum floor temperature



NOTE

This option is available only when the valve type selected is floor valve.

This function is used to define the maximum temperature of the valve sensor (if floor valve is selected). Once this temperature is reached, the valve is closed, the pump is disabled and main screen of the controller informs about floor overheating.

4.4.3.18 Sensor selection

This option concerns return sensor and external sensor. It is used to choose if the additional valve operation control should be based on the readings from the sensors of the valve module or the main controller sensors.

4.4.3.19 CH sensor

This options concerns CH sensor. It is used to choose if the additional valve operation should be based on the readings from the sensors of the valve module or the main controller sensors.

4.4.3.20 CH boiler protection

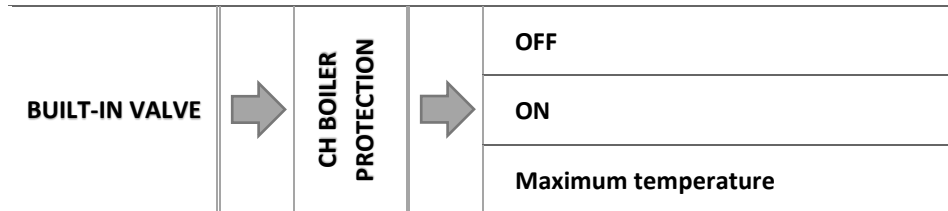

The protection against too high return temperature serves to prevent the hazardous growth in CH boiler temperature. The user sets the maximum acceptable return temperature. In case of the hazardous growth in temperature, the valve begins to open to house heating system in order to cool the CH boiler down.

4.4.3.20.1 Maximum temperature

The user defines the maximum acceptable CH temperature at which the valve will open.

4.4.3.21 Return protection

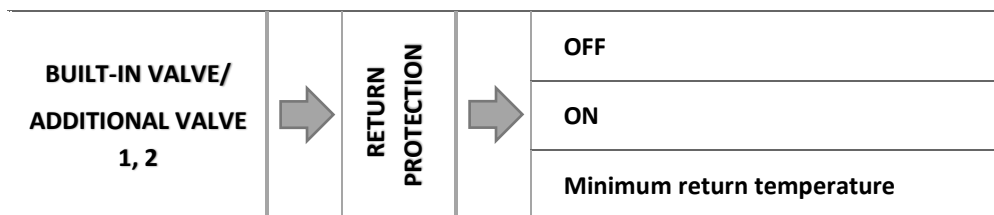

This function allows setting up CH boiler protection against too cool water returning from the main circulation, which could cause low-temperature boiler corrosion. The return protection involves closing the valve when the temperature is too low, until the short circulation of the boiler reaches the appropriate temperature.

4.4.3.21.1 Minimum return temperature

The user defines the minimum acceptable return temperature at which the valve will close.

4.4.3.22 Valve pump

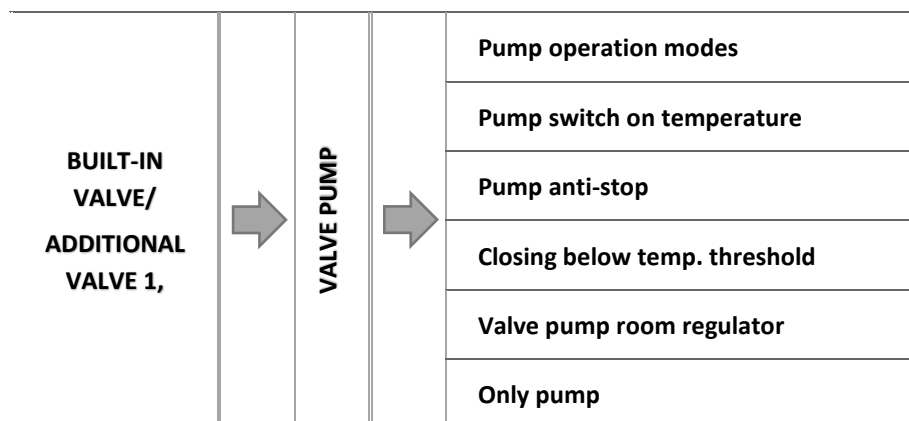

4.4.3.22.1 Pump operation modes

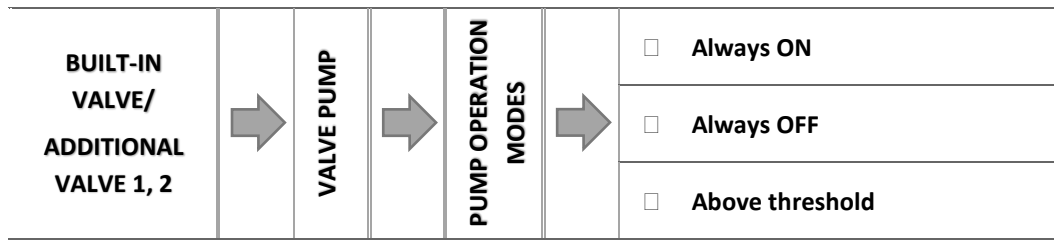

This option is used to select the pump operation mode.

- Always ON - the pump operates all the time, regardless of temperatures.
- Always OFF - the pump is permanently deactivated and the regulator controls only valve operation
- ON above threshold - the pump is activated above the pre-set activation temperature. If the pump is to be activated above the threshold, the user should also define the *threshold temperature of pump activation*. The temperature is read from CH sensor.

4.4.3.22.2 Pump switch on temperature

This option concerns the pump operating above the threshold (see: above). The valve pump is switched on when the CH boiler reaches the pump activation temperature.

4.4.3.22.3 Pump anti-stop

When this function is active, the valve pump is activated every 10 days for 2 minutes. It prevents stagnant water in the heating system outside the heating season.

4.4.3.22.4 Closing below temp. threshold

Once this function is activated (by selecting ON), the valve remains closed until the CH boiler sensor reaches the pump activation temperature.



NOTE

If i-1 is used as the additional valve module, *pump anti-stop* and *closing below temp. threshold* may be configured directly from the subordinate module menu.

4.4.3.22.5 Valve pump room regulator

When this option is active, the room regulator disables the pump when the pre-set temperature has been reached.

4.4.3.22.6 Only pump

When this option is active, the regulator controls only the pump while the valve is not controlled.

4.4.3.23 External sensor calibration

External sensor calibration is performed while mounting or after the regulator has been used for a long time, if the external temperature displayed differs from the actual temperature. Calibration range is from -10°C to +10°C.

4.4.3.24 Closing



NOTE

Function available after entering the code.

This parameter is used to decide if the valve should close or open once it has been switched off in CH mode. Select this option to close the valve. If this function is not selected, the valve will open.

4.4.3.25 Valve weekly control

This function enables the user to program daily changes of the pre-set valve temperature for particular time and day of the week. The settings range for the temperature changes is +/-10°C.

In order to activate weekly control, select *mode 1* or *mode 2*. Detailed settings of each mode are provided in the following sections: *Set mode 1* and *Set mode 2*. (separate settings for each day of the week) and *mode 2* (separate settings for working days and the weekend).



NOTE

In order for this function to work properly, it is necessary to set current date and time.

- **HOW TO CONFIGURE WEEKLY CONTROL**

There are 2 modes of settings weekly control:

MODE 1 – the user sets the temperature deviations for each day of the week separately

Configuring mode 1:

- ⇒ Select: Set mode 1
- ⇒ Select the day of the week to be edited
- ⇒ The following screen appears on the display:

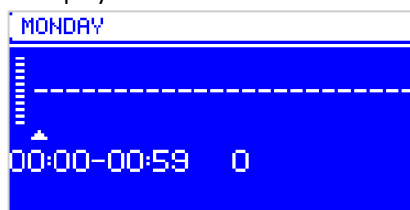

- ⇒ Use <+> <-> buttons to select the hour to be edited and press MENU to confirm.
- ⇒ Select CHANGE from the options which appear at the bottom of the screen by pressing MENU when this option is highlighted in white.
- ⇒ Increase or decrease the temperature as needed and confirm.
- ⇒ The range of pre-set temperature change is -10°C to 10°C.
- ⇒ If you want to copy the temperature change value for the next hours, press MENU button when the setting is selected. When options appear at the bottom of the screen, select COPY and use <+> <-> buttons to copy the settings into the previous or the following hour. Press MENU to confirm.

Example:

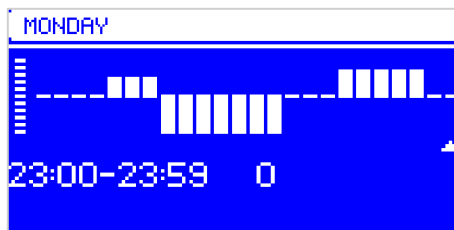

	Hour	Temperature - weekly control setting (+/-)
Monday		
PRE-SET	4 ⁰⁰ - 7 ⁰⁰	+5°C
	7 ⁰⁰ - 14 ⁰⁰	-10°C
	17 ⁰⁰ - 22 ⁰⁰	+7°C

If the pre-set CH boiler temperature is 50°C, on Mondays between 4⁰⁰ and 7⁰⁰ the CH boiler will increase by 5°C to reach 55°C; between 7⁰⁰ and 14⁰⁰ it will drop by 10°C, to reach 40°C, and between 17⁰⁰ and 22⁰⁰ it will increase to reach 57°C. If the pre-set CH boiler temperature is 50°C, on Mondays between 4⁰⁰ and 7⁰⁰ the CH boiler will increase by 5°C to reach 55°C; between 7⁰⁰ and 14⁰⁰ it will drop by 10°C, to reach 40°C, and between 17⁰⁰ and 22⁰⁰ it will increase to reach 57°C.

MODE 2 – the user sets the temperature deviations for all working days (Monday-Friday) and for the weekend (Saturday-Sunday) separately.

Configuring mode 2:

- ⇒ Select: Set mode 2.
- ⇒ Select the part of the week to be edited.
- ⇒ Follow the same procedure as in the case of Mode 1.

Example:

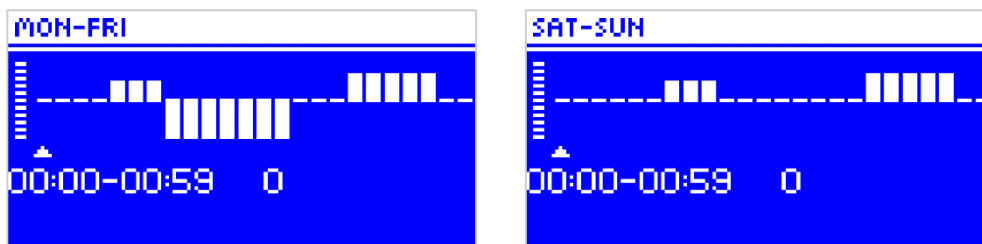

	Hour	Temperature - weekly control setting (+/-)
Monday - Friday		
PRE-SET	4 ⁰⁰ - 7 ⁰⁰	+5°C
	7 ⁰⁰ - 14 ⁰⁰	-10°C
	17 ⁰⁰ - 22 ⁰⁰	+7°C
Saturday - Sunday		
PRE-SET	6 ⁰⁰ - 9 ⁰⁰	+5°C
	17 ⁰⁰ - 22 ⁰⁰	+7°C

If the pre-set CH boiler temperature is 50°C, from Monday to Friday between 4⁰⁰ and 7⁰⁰ the CH boiler will increase by 5°C to reach 55°C; between 7⁰⁰ and 14⁰⁰ it will drop by 10°C, to reach 40°C, and between 17⁰⁰ and 22⁰⁰ it will increase to reach 57°C.

At the weekend, between 6⁰⁰ and 9⁰⁰ the temperature will increase by 5°C to reach 55°C, and between 17⁰⁰ and 22⁰⁰ it will increase to reach 57°C.

4.4.3.26 Factory settings

This function enables the user to restore the factory settings for a particular valve. Restoring factory settings changes the type of valve selected to CH valve.

4.4.4 Time settings

This parameter is used to set current time.

⇒ Use <+> and <-> to set the hour and minutes separately.



4.4.5 Date settings

This parameter is used to set current date.

⇒ Use <+> and <-> to set day, month and year separately.

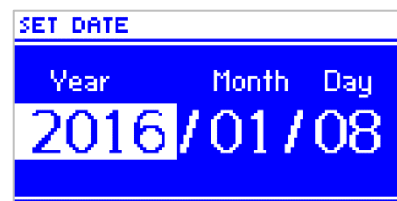

4.4.6 GSM module



NOTE

This type of control is available only after purchasing and connecting an additional controlling module ST-65 which is not included in the standard controller set.

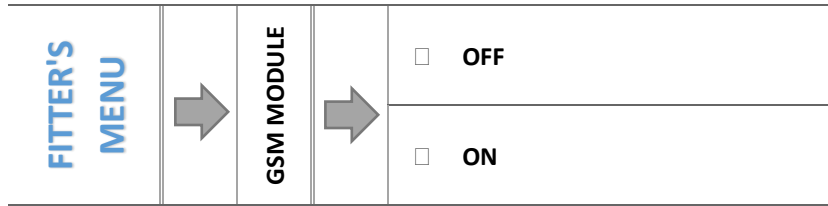

⇒ If the controller is equipped with additional GSM module, it is necessary to activate it by selecting *ON*.

GSM Module is an optional device which, cooperating with the controller, enables the user remote control of the CH boiler operation via mobile phone. The user is sent an SMS each time an alarm occurs. Moreover, after sending a certain text message, the user receives feedback on the current temperature of all the sensors. Remote change of the preset temperatures is also possible after entering the authorisation code.

GSM Module may operate independently of the CH boiler controller. It has two additional inputs with temperature sensors, one contact input to be used in any configuration (detecting closing/opening of contacts) and one controlled output (e.g. a possibility of connecting an additional contractor to control any electric circuit)

When any of the temperature sensors reaches the pre-set maximum or minimum temperature, the module automatically sends an SMS message with such information. A similar procedure is used in the case of opening or closing of the contact input, which may be used as a simple means of property protection.

4.4.7 Internet module



NOTE

This type of control is available only after purchasing and connecting an additional controlling module ST-505 which is not included in the standard controller set.

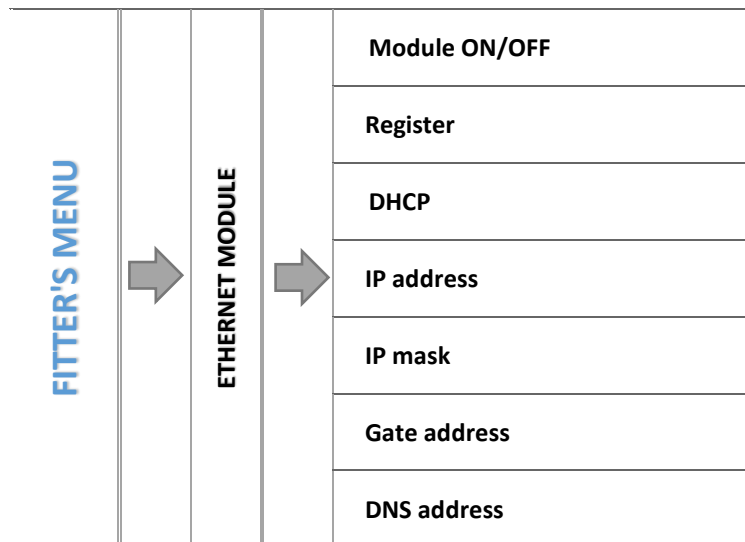

- ⇒ Before registering the module, it is necessary to create user's account on emodul.pl (if you do not have one).

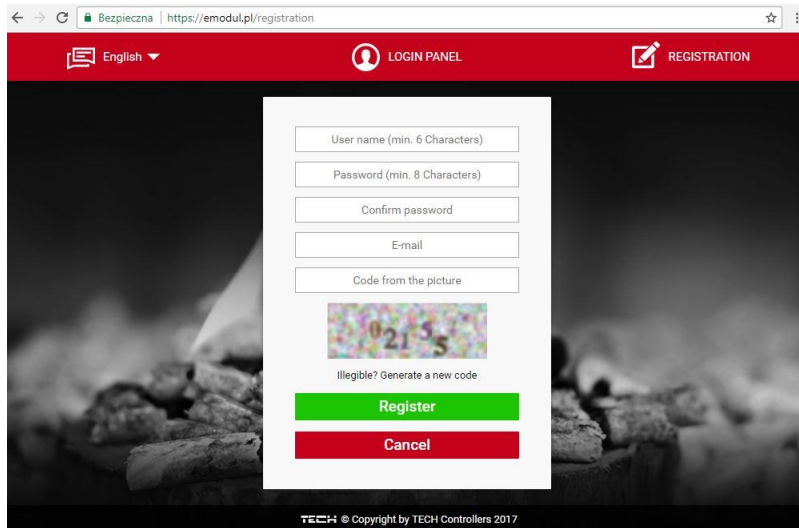

- ⇒ Once the module has been connected properly, select *Module ON*.
- ⇒ Next select *Registration*. The controller will generate a code.
- ⇒ Log on emodul.pl, go to Settings tab and enter the code which appeared on the controller screen.
- ⇒ It is possible to assign any name or description to the module as well as provide phone number and e-mail address to which the notifications will be sent.
- ⇒ Once generated, the code should be entered within an hour. Otherwise, it will become invalid and it will be necessary to generate a new one.

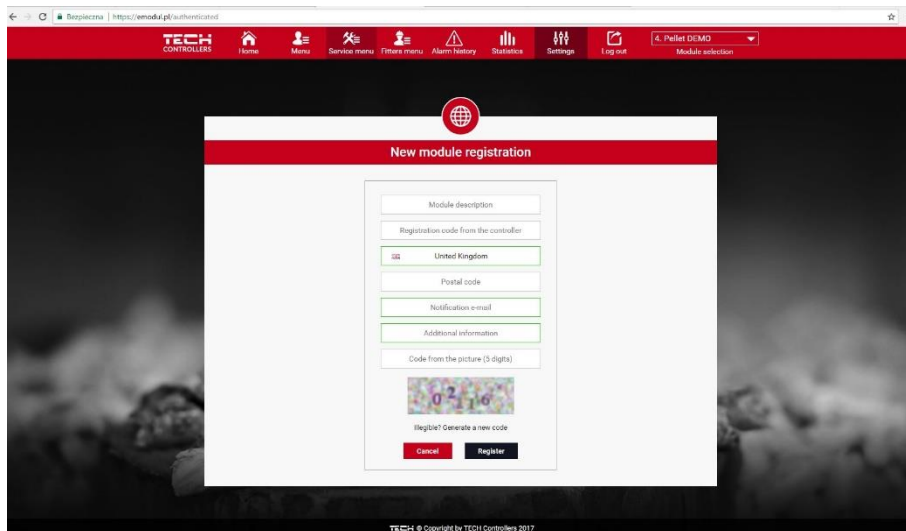

- ⇒ Internet module parameters such as IP address, IP mask, gate address enc. may be set manually or by selecting DHCP option.

Internet module is a device enabling the user remote control of the CH boiler via the Internet. [Emodul.pl](https://emodul.pl) enables the user to control the status of all CH boiler system devices and temperature sensors on the home computer screen, tablet or smart phone. Tapping on corresponding icons, the user may adjust the operation parameters, pre-set temperatures for pumps and valves enc.



4.4.8 External sensor calibration

External sensor calibration is performed while mounting or after it has been used for a long time, if the external temperature displayed differs from the actual temperature. Calibration range is from -10°C to $+10^{\circ}\text{C}$. *Averaging time* parameter defines the frequency at which the external sensor readings are sent to the controller.

4.4.9 Software update

This function is used to update/change the software version installed in the controller.

NOTE

- It is advisable to have software update conducted by a qualified fitter. Once the change has been introduced, it is impossible to restore previous settings.
- The memory stick which is going to be used to save the setup file should be empty (preferably formatted).

Make sure that the file saved on the memory stick has exactly the same name as the downloaded file so that it is not overwritten.

- Mode 1:
 - ⇒ Insert the memory stick with the software into the controller USB port.
 - ⇒ Select *Software update* (in the fitter's menu).
 - ⇒ Confirm controller restart
 - Software update starts automatically.
 - The controller restarts
 - Once restarted, the controller display shows the starting screen with software version
 - Once the installation process is completed, the display shows the main screen.
 - ⇒ When software update has been completed, remove the memory stick from USB port.
- Mode 2:
 - ⇒ Insert the memory stick with the software into the controller USB port.
 - ⇒ Reset the device by unplugging it and plugging it back in.
 - ⇒ When the controller starts again, wait until the software update process starts.
 - The following part of software update is the same as in Mode 1.

4.4.10 Factory settings

This option is used to restore the factory settings of the fitter's menu.

5 PROTECTIONS AND ALARMS

In order to ensure safe and failure-free operation, the regulator has been equipped with a range of protections. In case of alarm, a sound signal is activated and an appropriate message appears on the screen.



ALARM/NOTIFICATION	DESCRIPTION
TEMPERATURE ALARM	It stops the valve temperature control and sets the valve in its safe position (floor valve - closed; CH valve-open).
VALVE SENSOR	No sensor connected/ improperly connected sensor/ sensor damage. The sensor is essential for proper valve operation so it needs to be replaced immediately.
RETURN SENSOR	This alarm occurs when return protection function is active and the sensor is damaged. Check the sensor mounting or replace if damaged. It is possible to deactivate the alarm by disabling return protection function
WEATHER SENSOR	This alarm occurs when the external temperature sensor is damaged. The alarm may be deactivated when undamaged sensor is installed properly. The alarm does not occur in other operation modes than 'Weather-based control' or 'Room control with weather-based control'.
CH SENSOR DAMAGED	This alarm may occur if the device has been improperly configured with the sensor, the sensor has not been connected or has been damaged.
DHW SENSOR DAMAGED	In order to solve the problem, check the connections on the terminal block, make sure the connection cable is not damaged and there is no short circuit, check if the sensor works properly by connecting another sensor in its place and checking its readings.

6 TECHNICAL DATA

No.	Specification	
1	Power supply	230V ±10% /50Hz
2	Max. power consumption	3W
3	Operation temperature	5÷50°C
4	Pump max. output load	0,5A
5	Valve max. output load	0,5A
6	Potential-free cont. nom. out. load	230V AC / 0,5A (AC1) * 24V DC / 0,5A (DC1) **
7	Sensor thermal resistance	-30÷99°C
8	Fuse	1,6A

* AC1 load category: single-phase, resistive or slightly inductive AC load.

** DC1 load category: direct current, resistive or slightly inductive load.

TECH CONTROLLERS

EU DECLARATION OF CONFORMITY

Hereby, we declare under our sole responsibility that **controller EU- i-1 CWU** manufactured by TECH STEROWNIKI II Sp. z o.o., head-quartered in Wieprz Biała Droga 31, 34-122 Wieprz, is compliant with Directive **2014/35/EU** of the European Parliament and of the Council of 26 February 2014 on the harmonisation of the laws of Member States relating to **the making available on the market of electrical equipment designed for use within certain voltage limits** (EU OJ L 96, of 29.03.2014, p. 357), **Directive 2014/30/EU** of the European Parliament and of the Council of 26 February 2014 on the harmonisation of the laws of Member States relating to **electromagnetic compatibility** (EU OJ L 96 of 29.03.2014, p.79), Directive **2009/125/EC** establishing a framework for the setting of ecodesign requirements for energy-related products as well as the regulation by the MINISTRY OF ENTREPRENEURSHIP AND TECHNOLOGY of 24 June 2019 amending the regulation concerning the essential requirements as regards the restriction of the use of certain hazardous substances in electrical and electronic equipment, implementing provisions of Directive (EU) 2017/2102 of the European Parliament and of the Council of 15 November 2017 amending Directive 2011/65/EU on the restriction of the use of certain hazardous substances in electrical and electronic equipment (OJ L 305, 21.11.2017, p. 8).

For compliance assessment, harmonized standards were used:

PN-EN IEC 60730-2-9:2019-06,

PN-EN 60730-1:2016-10,

EN IEC 63000:2018 RoHS.

Paweł Jura

Janusz Master

Prezesa firmy

Wieprz, 11.02.2026

**TECH
TECH
CONTROLLERS**

Central headquarters:

ul. Biała Droga 31, 34-122 Wieprz

Service:

ul. Skotnica 120, 32-652 Bulowice

phone: **+48 33 875 93 80**

e-mail: **serwis@techsterowniki.pl**

www.tech-controllers.com